

# auto electrical parts

## Technical Information Sheet

### Part No. 0-525-16

12/24 volt 0 to 10 bar marine oil pressure gauge, 90° sweep dial. LED illumination, plastic cased with screw collar type fitting. Supplied with 1/8" NPTF sender.

### Additional Information

Illumination white. Sender has as isolated earth and Twin M4 screw termination, replacement part 0-525-86.



### Technical Drawing (not to scale)

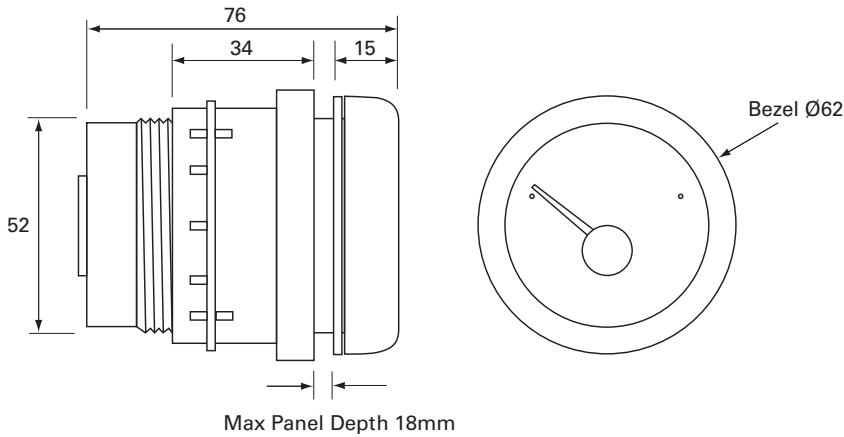

### Sender unit

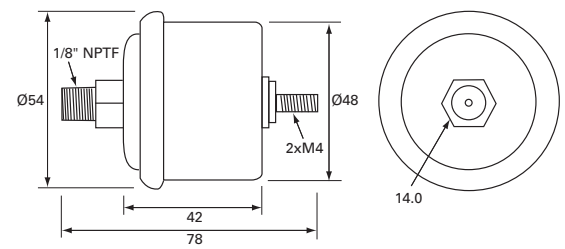

### Specification

Type	Panel mount marine water temperature gauge
Voltage	12/24 volt DC
Scale	90° sweep, 0 - 10 bar
Illumination	4 LED white
LED current	33mA
Cable length	520mm
Panel Cut out	52mm
Max panel depth	18mm
Protection	IP65 (front)
Weight	290g (inc. sender)
Dimensions	See diagram

### Sender

Resistance	3 - 160Ω
Material	JIS G3141 steel
Thread	1/8" NPTF

The information contained in this document is correct to the best of our knowledge at the time of printing. However, specifications may change at any time without notice.